

GENIUS

THE INGENIOUS ENERGY-SAVING
CONTROLLER

INSTALLATION & OPERATION GUIDE



GENIUS LED100

TABLE OF CONTENTS

GENIUS LED 100

The following operating instructions will guide you during commissioning and use of your GENIUS LED 100 and answer all essential questions. Please read these operating instructions carefully before using your GENIUS LED 100.

1.	Scope of Delivery	3
2.	Warning / Safety	4
3.	Introduction GENIUS LED 100	5
4.	Controls and Display Elements	6
5.	Installation and Start-Up	7
	5.1 Inserting / Changing batteries	7
	5.2 Installation at the Radiator	8
	5.3 Adapters	9
	5.4 Adaptation	10
	5.5 Disassembly	10
6.	Main Functions	11
	6.1 Temperature Setting	11
	6.2 Self-Learning-Function	11
	6.3 Fast-Link-Technology	12
7.	GENIUS App	13
	7.1 Settings (App)	13
	7.2 Temperature (App)	14
	7.3 Heating Profile (App)	14
	7.4 Holiday Function (App)	15
	7.5 Support (App)	15
8.	Further Functions	16
9.	Cleaning and Storage	16
10.	Error Messages and Help	17
11.	Technical Specifications	18
12.	Support and Contact	18
13.	Environmental Information	19
14.	Warranty	19

1. SCOPE OF DELIVERY

GENIUS LED 100

- 1x GENIUS LED 100
- 1x Quick Start Guide
- 3x Adapters (Danfoss RA / RAV / RAVL)
- 1x Screw for adapter

NOTE: The following figures are for illustrative purpose only and can differ from the real product.

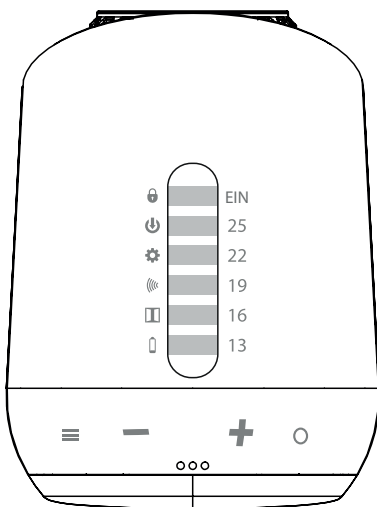

GENIUS LED 100
Energy-saving controller

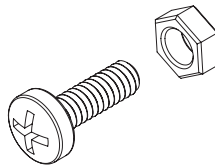

Screw
for adapter

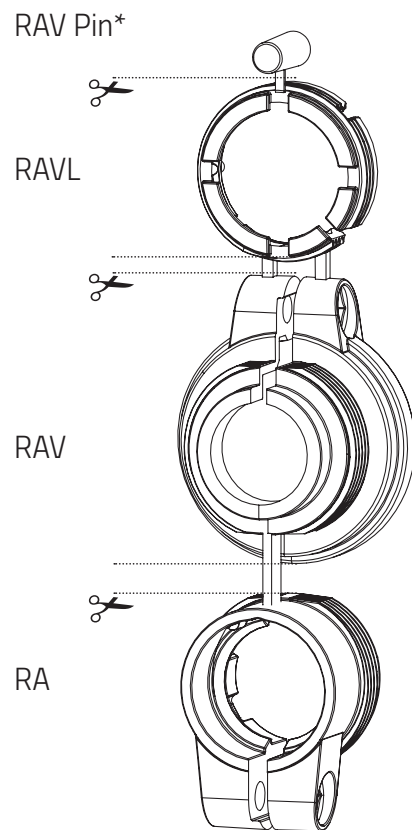

* When using the RAV adapter, you need the RAV Pin for the extension of the valve stem.

NOTE: Please check the delivery scope for completeness.

2. WARNING / SAFETY

GENIUS LED 100

WARNING! This signal word indicates a hazard with a medium degree of risk which, if not avoided, may result in death or serious injury.

NOTE! This signal word warns of possible material damage.

SAFETY INSTRUCTIONS

- GENIUS LED100 is designed for use in buildings.
- Operate GENIUS LED100 only as described in the user manual
- GENIUS LED100 should only be put to use in a dry and dust-free place, away from direct sunlight.
- Do not keep using the device when there is obvious damage.
- GENIUS LED100 may not be rebuilt, modified or opened



WARNING! RISK OF EXPLOSION!

Improper handling of batteries can lead to explosion.

- Do not heat batteries and do not throw batteries into an open fire.
- Do not place batteries in direct sunlight.
- Protect batteries from excessive heat.
- Do not short-circuit the batteries.
- Never attempt to charge non-rechargeable batteries.
- Never disassemble batteries.
- Do not use new and used batteries together.
- Observe the correct polarity (+/-) when inserting the batteries.
- Before inserting the batteries, clean the batteries and the contacts in the thermostat.

WARNING! RISK OF ACID BURNS!

Leaking battery acid can lead to burns.

- Avoid contact of battery acid with skin, eyes and mucous membranes.
- In case of contact with battery acid, rinse the affected areas immediately with plenty of clear water and consult a doctor.

WARNING! RISK OF INJURY!

When children play with the thermostat or packaging, they might swallow small parts and suffocate.

- Do not let children play with the thermostat or packaging.
- Keep batteries away from children. Seek medical attention immediately if batteries are swallowed.

WARNING! SENSITIVITY TO LIGHT!

Some people may have epileptic seizures if they are exposed to certain light effects, even if no previous incidents are known.

3. INTRODUCTION GENIUS LED100

GENIUS LED 100

Thank you for purchasing a product from Eurotronic Technology GmbH. This device is designed to adjust the temperature in your rooms comfortably and completely according to your needs while helping you to reduce your heating costs effectively.

All development and production are 100% „Made in Germany“, guaranteeing the highest quality and technology standards. These operating instructions will help you to put your device into operation quickly and easily.

GENIUS LED 100

GENIUS LED 100 is an energy-saving controller for radiators equipped with Fast-Link technology for modern and simple operation. It regulates your room temperature automatically according to your settings by means of a self-learning function or conveniently via your smartphone using Fast-Link.

Bis zu 30%
Save heating costs through energy-efficient control.

Touch control enables perfect control as well as simple and clear operation.

Fast-Link technology transmits your heating plan, individually created in the app, contactlessly.

Simple installation without intervention in the heating system.

Self-Learning function records your everyday routines and automatically creates an individual heating profile for you.

4. CONTROLS AND DISPLAY ELEMENTS

GENIUS LED 100

To enter the menu, press the **MENU** button. Use the PLUS/MINUS buttons to navigate through the menu.

In normal mode, you can set the temperature with **PLUS** and **MINUS**.

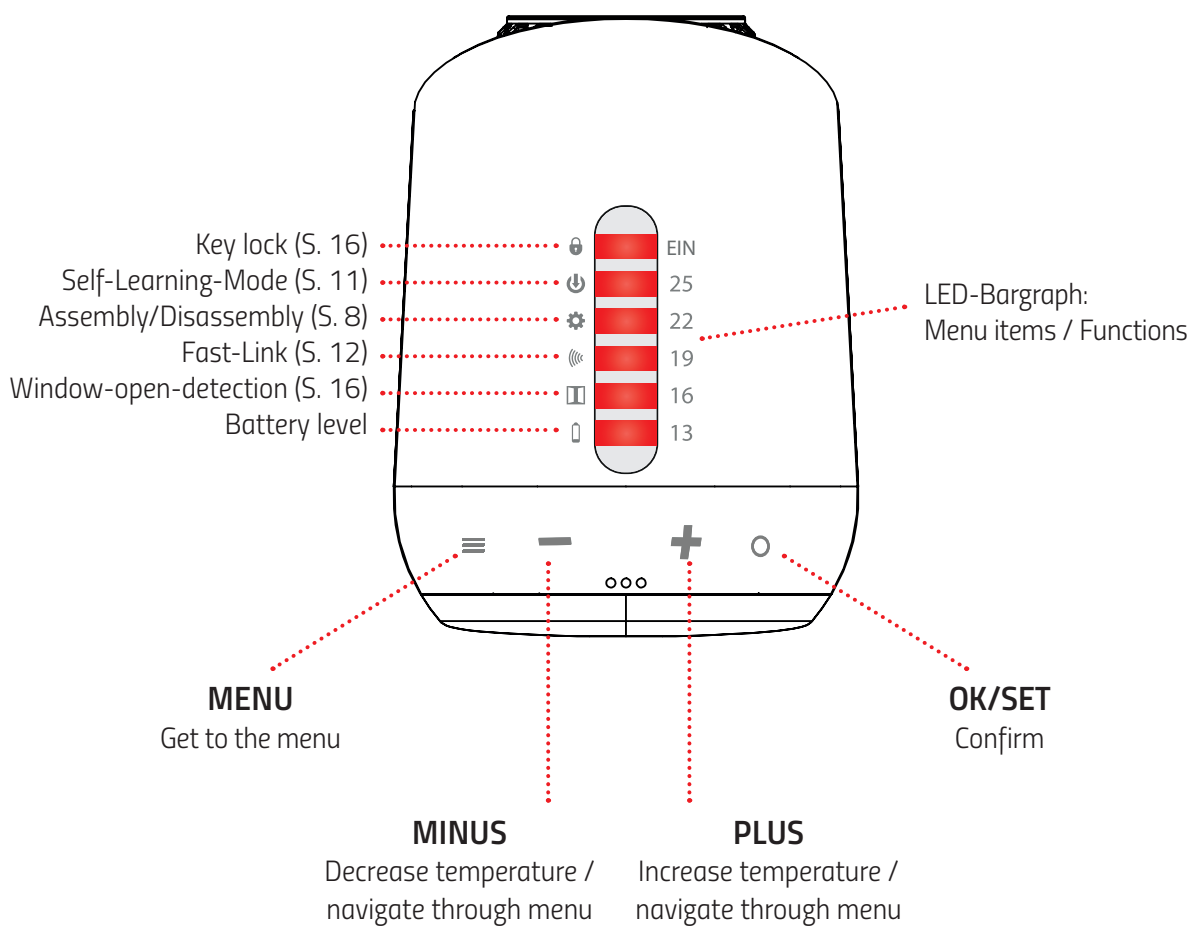

Manual Operation:

Use **PLUS/MINUS** to manually change the room temperature at any time. In AUTO mode, this manually set temperature remains until the next setting point. GENIUS LED 100 then switches back to the set heating programme.

5. INSTALLATION AND START-UP

GENIUS LED 100

5.1 INSERTING/CHANGING BATTERIES

1. Remove the battery cover by pulling it upwards at the notch (Fig. 1).
2. Now insert the batteries. **Pay attention to the correct polarity! Do not use rechargeable batteries.**
3. Place the battery cover back on the GENIUS LED 100 (Fig. 2) by pressing until it clicks.

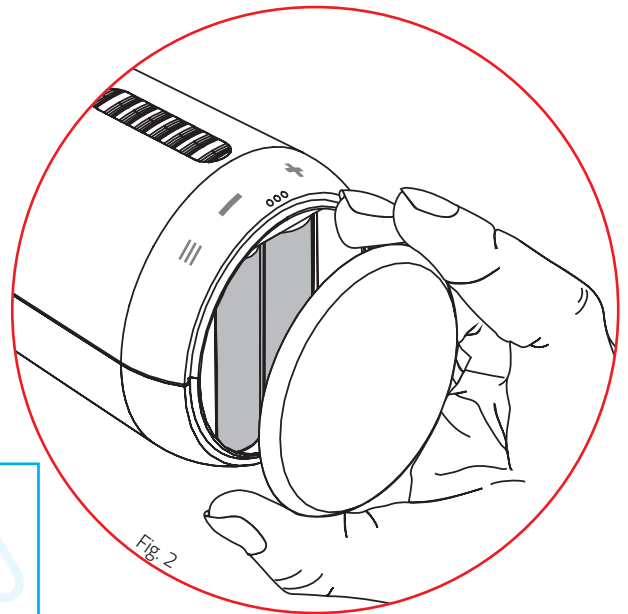
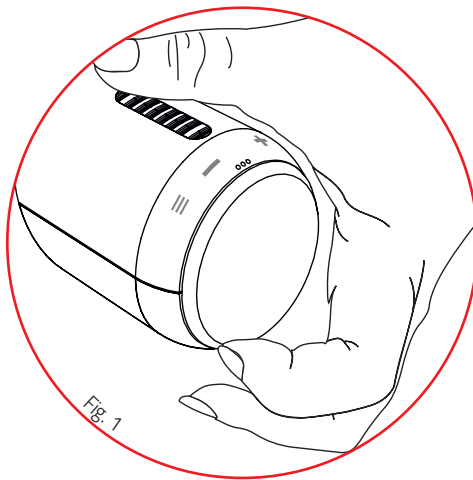

BATTERY:

If the batteries are weak, the battery LED will flash continuously until the batteries are changed.



5.2 INSTALLATION AT THE RADIATOR

GENIUS LED 100

GENIUS LED 100 can easily be mounted on all known valve bodies (see adapter list at: <https://eurotronic.org/service/faq>).

1. Unscrew the old thermostatic head completely, loosen the fastening and pull it off the valve (Fig. 3)
2. If necessary, select a suitable adapter and mount it on the valve (Fig. 4)
3. Screw the thermostat onto the valve or adapter by turning the union nut clockwise (Fig.5).

CAUTION:

Make sure that the device is in the installation mode even if it is installed/removed later.
Only assemble/disassemble in this position.

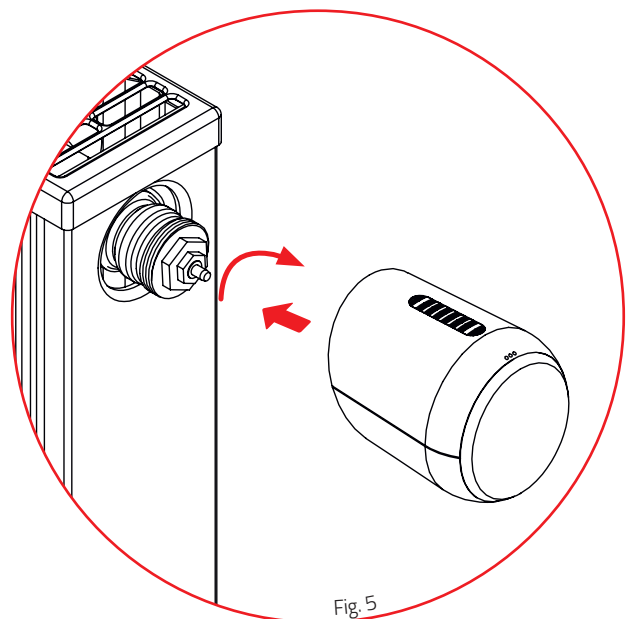
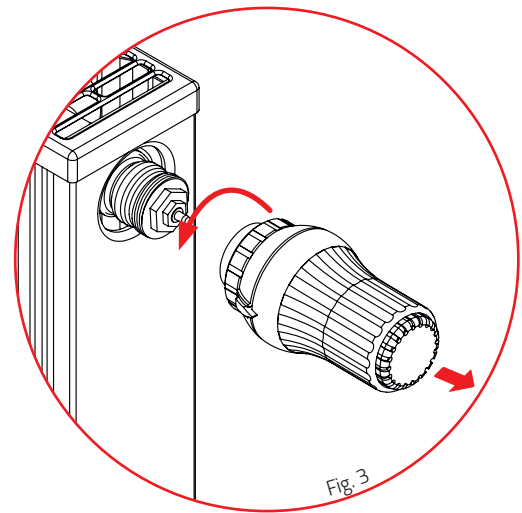
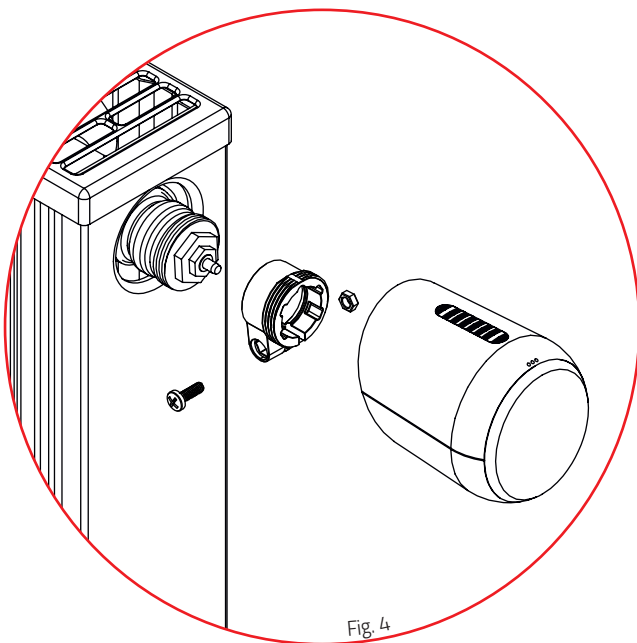

5.3 ADAPTERS

GENIUS LED 100

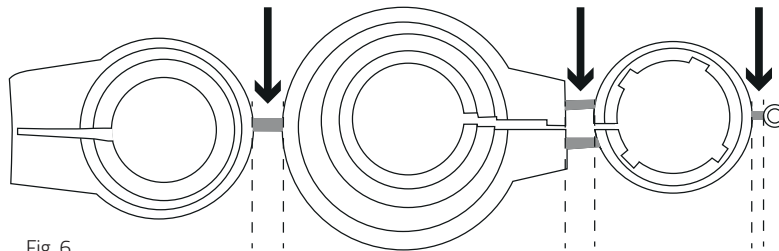

Fig. 6

HINWEIS:

Remove the connectors of the plastic adapters completely (Fig. 6) before using one of the included adapters! For Danfoss RA/RAV, use the enclosed screw and nut.



For the following valves no adapter is required:

Heimeier; Junkers Landys+Gyr; MNG; Honeywell; Braukmann, as these have a thread of M30 x 1,5 mm. The adapters for Danfoss RAV (pin must be plugged on the valve tappet) Danfoss RA and Danfoss RAVL are included.

For the following valves you need an adapter:

Herz M28 x 1,5 mm; Comap M28 x 1,5 mm; Vaillant 30,5 mm; Oventrop M30 x 1,0 mm; Meges M38 x 1,5 mm; Ondal M38 x 1,5 mm; Giacomini 22,6 mm; Rosswainer M33 x 2,0 mm; Markaryd M28 x 1,0 mm; Ista M32 x 1,0 mm; Vama M28 x 1,0 mm; Pettinaroli M28 x 1,5 mm; T+A M28 x 1,5 mm; Gampper 1/2/6; Danfoss RA/RAV/RAVL.

For additional adapters, please visit: <http://shop.eurotronic.org>

If you are not sure which valve you have, please visit: www.eurotronic.org/produkte/faq/ and check the adapter list.

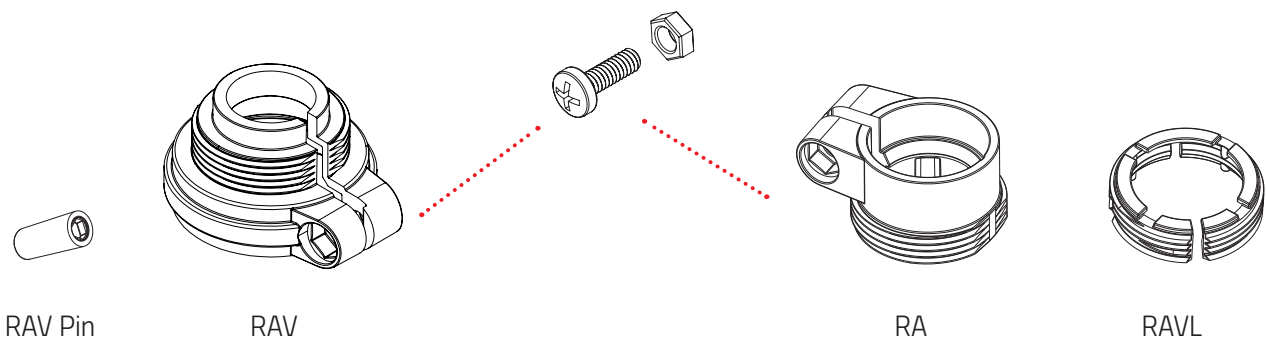

RAV Pin

RAV

RA

RAVL

5.4 ADAPTATION

GENIUS LED 100

After installation, GENIUS LED 100 can start adapting. The LED for Assembly/Disassembly ⚙️ is already flashing, confirm the adaptation by pressing and holding the OK/SET button (3 seconds). The adaptation starts after confirmation. The device now adapts to the stroke of your valve body. To do this, the valve is now opened and closed several times to learn the respective end points. A running light is indicated by the LEDs. After successful adaptation, the GENIUS LED 100 switches to normal operation and the LEDs indicate the setpoint temperature. After approx. 5 seconds the thermostat switches to standby mode.

- | If a new adaptation is necessary, e.g. if your radiator does not become cold in the OFF position, please select Assembly/Disassembly ⚙️ in the menu. Confirm with **OK/SET** (3 seconds) and start the adaptation again
- | When the Assembly/Disassembly LED ⚙️ flashes again, place the GENIUS LED 100 on the radiator valve and then briefly remove the batteries to reset.

5.5 DISASSEMBLY

To remove the GENIUS LED 100, press the MENU button on your controller. Use **PLUS/MINUS** to navigate to the menu item for Assembly/Disassembly and confirm with **OK/SET**. A running light is indicated by the LEDs. Wait briefly until the setting LED flashes. Now turn the union nut counterclockwise and remove the GENIUS LED 100 from the valve (Fig. 7).

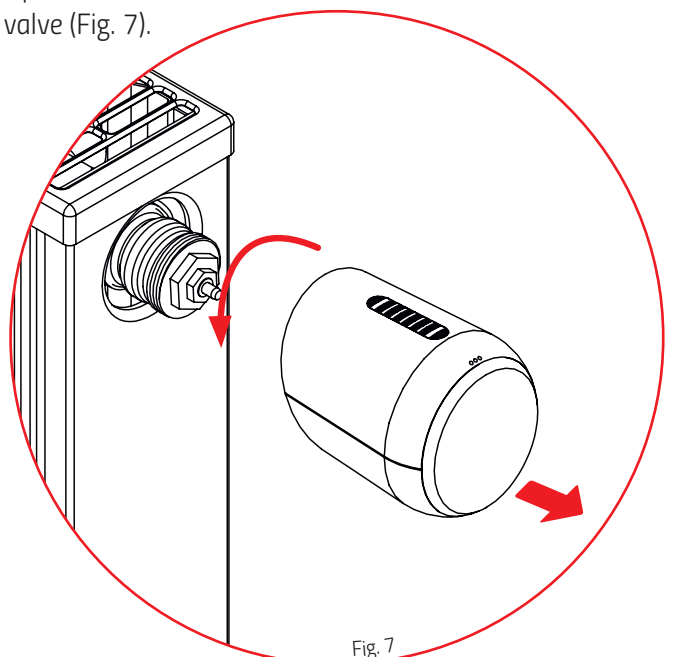

6. MAIN FUNCTIONS

GENIUS LED 100

6.1 TEMPERATURE SETTING

The temperature can be set as desired using the **PLUS** and **MINUS** buttons. The temperature is always increased or decreased in 1.5° steps.

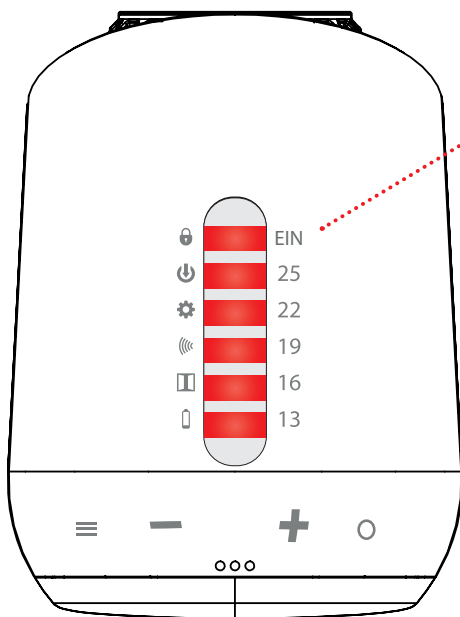

All 6 LEDs on > 28° = heating ON (valve fully open, no regulation)

LED 1 to 5 on, 6 flashes: 28°

LED 1 to 5 an: 26,5°

LED 1 to 4 an, 5 flashes: 25°

LED 1 to 4 an: 23,5°

LED 1 to 3 an, 4 flashes: 22°

LED 1 to 3 an: 20,5°

LED 1 to 2 an, 3 flashes: 19°

LED 1 to 2 an: 17,5°



LED 1 to, 2 flashes: 16°

LED 1 to: 14,5

LED 1 flashes: 13°

no LED on: < 8° = heating OFF (anti-freeze function active)

6.2 SELF-LEARNING-FUNCTION

To start the self-learning function (running time 24 hours), select the menu item Self-learning function  in the **MENU**. To do this, use **PLUS** and **MINUS** to navigate through the menu until the Self-learning function LED  lights up. Now confirm with OK/SET. The thermostat then goes into normal operation and displays the temperature via the LEDs. All temperature changes that you make on the thermostat in the next 24 hours are now stored. After the 24 hours have elapsed, heating is now carried out every day according to the same stored scheme.

6.3 FAST-LINK-TECHNOLOGY

GENIUS LED 100

With Fast-Link technology and our app, you can quickly and easily make settings on your controller and create heating profiles using your smartphone. Using Fast-Link technology, the settings are then transmitted to the controller simply by holding the smartphone on to it.

To use Fast-Link you need the Eurotronic GENIUS App. Download the free „Eurotronic GENIUS“ application from the Apple App Store (iOS) or Google Play Store (Android) to your smartphone or tablet.

NOTE: To ensure trouble-free transmission, set the brightness of your display to the highest level. No energy-saving mode or similar must be activated.

1. Remove the battery cover (Fig.9).
2. Press the **MENU** button on your controller. Use **PLUS/MINUS** to navigate through the menu until the Fast-Link LED lights up. Confirm with **OK/SET**.
3. Press the „Transmit settings“ button in the app and hold your smartphone close to the device as shown in Fig.10.

Fast-Link-transmission was **successful**.

→ Fast-Link-LED  lights up for 3 seconds to confirm.

Fast-Link-transmission was **not successful**.

→ Fast-Link-LED  flashes at increased frequency (4 Hz).

NOTE: Both devices, the smartphone and the device, need to be set to FAST-LINK Mode.

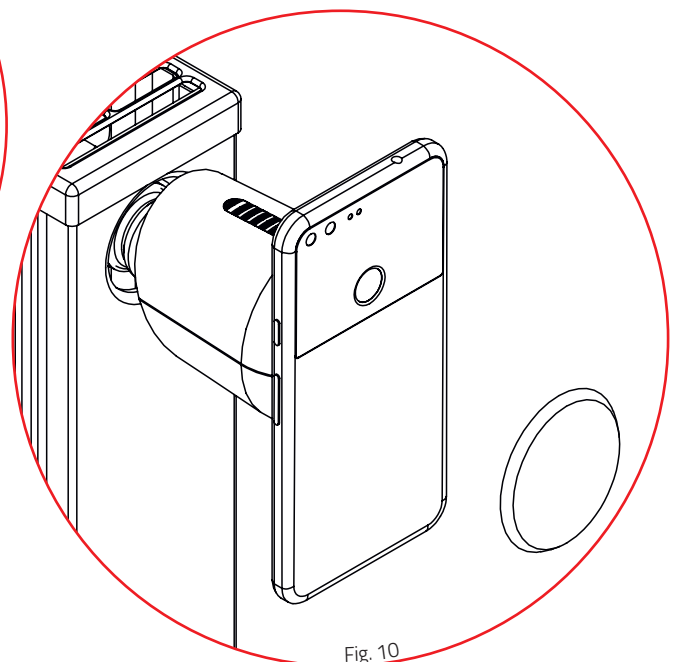
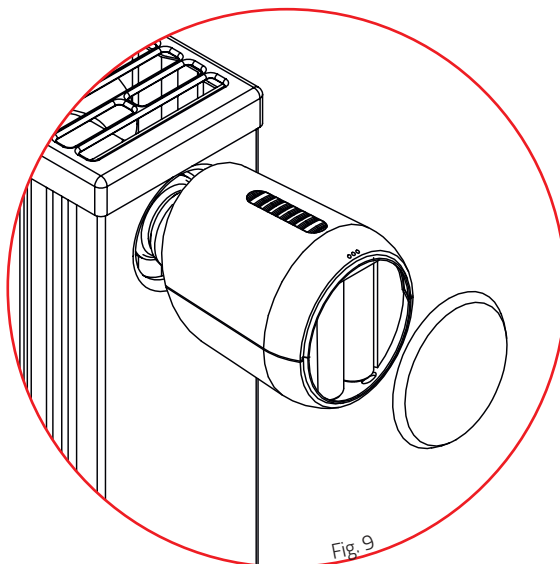
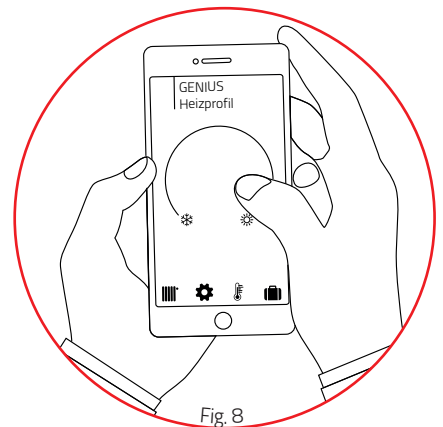

7. GENIUS APP

GENIUS LED 100

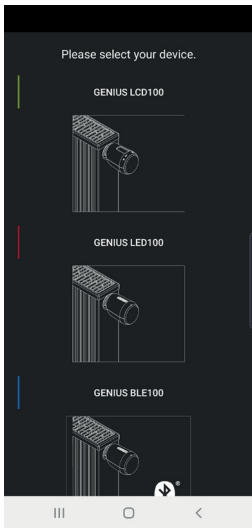

Please select your device: GENIUS LED100.

Back to the home page.

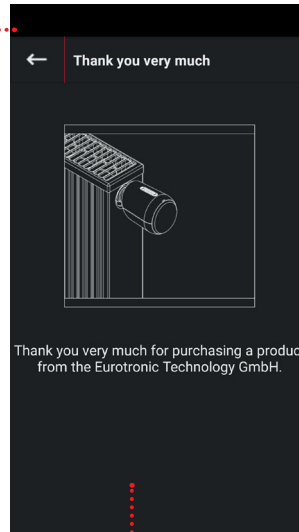

By „wiping further“ you can display the assembly instructions in four steps.

NOTE:

Please remember to transmit the data via Fast-Link as soon as you have made a change in the app.



7.1 SETTINGS (APP)

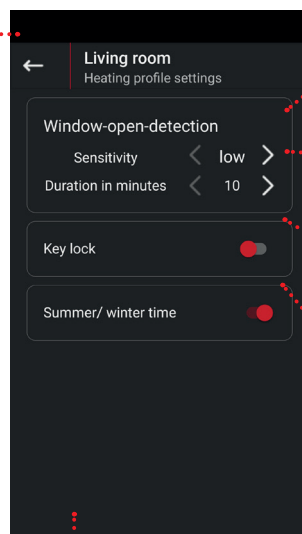
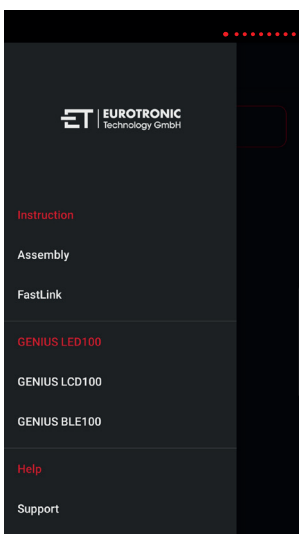

Select the sensitivity of the temperature setting (high, medium, low).

Set the desired period of time for which the valve is to remain closed.

By activating the child lock, manual operation on the controller is blocked.

If you activate the „Summer/winter time“ toggle switch, the time changeover is carried out automatically.

In the menu bar you can switch between the menu items: settings, temperature, heating profile and holiday.

7.2 TEMPERATURE (APP)

GENIUS LED 100

The temperature shown above is the one currently being set.

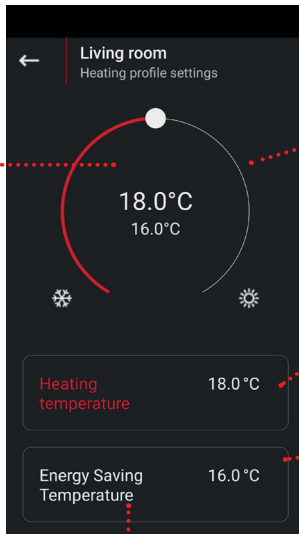

With the setting wheel you can set your comfort temperature and economy temperature, which will then be used for your

Determine the temperature with which the heating is to be carried out during the heating times. To do this, select the „Comfort temperature“ button and set the temperature using the setting

Determine how far the temperature should be lowered during the saving times. To do this, select the „Economy temperature“ button and set the temperature using the setting wheel.

In the menu item „Temperature“ you may set your comfort and economy temperatures.

NOTE:

Please keep in mind, to transmit the data you have changed in the App via Fast-Link.



7.3 HEATING PROFILE (APP)

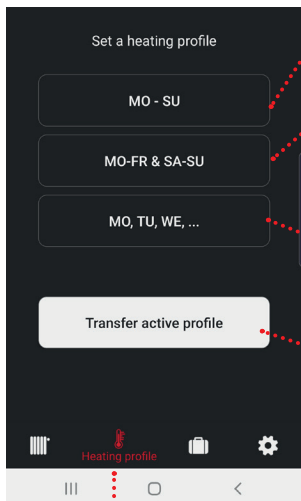

Here you can create a heating profile for the **whole week**.

Here you can create different heating profiles for the **week-days** and **weekends**.

Here you can create an individual heating profile for **each day**.

After you have made your settings, you can transmit your heating profile via Fast-Link.

In the menu item „Heating profile“ you can create individual heating profiles.

Back to the overview.

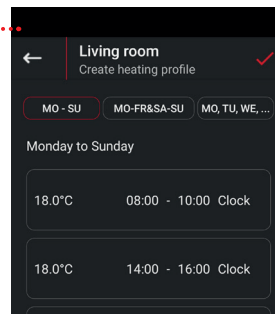

After defining the heating times, confirm with the check mark.

You can transmit simply.

You can transmit your settings at triple speed.

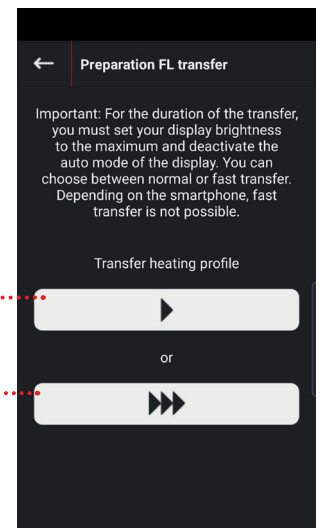

7.4 HOLIDAY FUNCTION (APP)

GENIUS LED 100

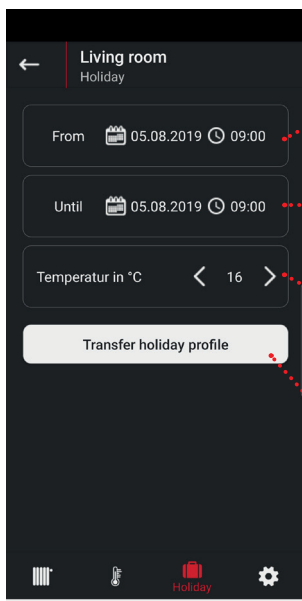

Select the time of your departure.

Select the time of your return.

Determine the room temperature for the duration of your absence.

After you have created your holiday profile, transmit it via Fast-Link.

The menu item „Holiday“ allows you to create a holiday profile for the time of your absence.

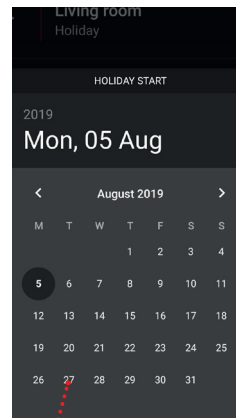

Select your month and day and confirm with OK.

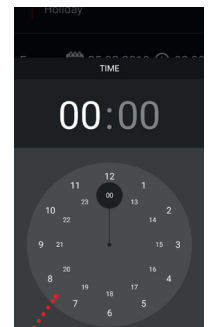

Select your month and day and confirm with OK.

NOTE:

Please keep in mind, to transmit the data you have changed in the App via Fast-Link.



7.5 SUPPORT (APP)

Back to the overview.

Leave the checkmark ticked so that we can identify your problem more quickly.

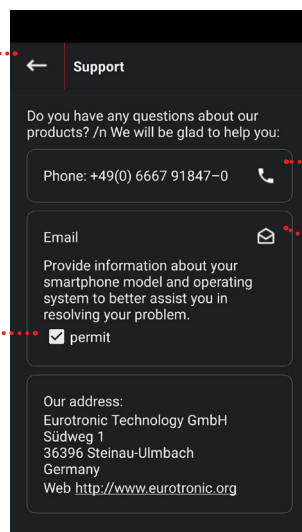



If you have any questions, please do not hesitate to contact us by telephone.

If you have any questions, you can send us an e-mail.

8. FURTHER FUNCTIONS

GENIUS LED 100

Window-open-detection: The GENIUS LED 100 automatically closes the heating valve to save energy if you open a window and the temperature thereby drops significantly. If window-open detection is active, the window-open detection LED  lights up. The LED lights up until the set time has elapsed and the thermostat returns to normal mode.

Key lock: Please select the menu item Key lock in the menu. To do this, use PLUS/MINUS to navigate through the menu until the Key lock LED  lights up. Now confirm with OK/SET. Manual operation on the controller is now disabled. To unlock the key lock, press and hold the MENU and OK/SET buttons simultaneously for about 10 seconds.

NOTE: While the key lock is active, the LED next to the key lock icon lights up when an attempt is made to make changes to the thermostat.

When the key lock is unlocked, the Key Lock LED turns on and off briefly. The current temperature is then displayed via the illuminated LEDs.



Anti-freeze and anti-scale function: The anti-freeze and anti-scale functions are automatically active.

Anti-freeze function: If the temperature drops below 8°C, GENIUS LED 100 opens the valve until the temperature rises above 8°C again. This prevents the radiators from freezing.

Anti-scale function: To prevent the radiator valves from scaling, GENIUS LED 100 regularly carries out a scaling protection run.

Resetting: If you wish to reset the radiator controller to the factory settings, press and hold the PLUS/MINUS buttons simultaneously for at least 10 seconds. A running light is indicated by the LEDs. After successful reset the LED for Assembly/Disassembly  starts flashing.

The procedure is now the same as for initial commissioning. Now proceed as for the initial commissioning.

9. CLEANING AND STORAGE

RISK OF DAMAGE! Improper handling of the thermostat can lead to damage.





- Do not immerse the thermostat in water or other liquids.
- Do not use aggressive cleaning agents, brushes with metal or nylon bristles or sharp or metallic cleaning objects such as knives, hard spatulas and the like. These can damage the surfaces.
- Clean the thermostat with a soft, dry cloth. Do not exert pressure on the display.



Switch off the device and remove the batteries if you will not be using the device for a long time. Store the device in a dry, dust-free place.

10. ERROR MESSAGES AND HELP

GENIUS LED 100

Error	Cause	Solution
Radiator does not warm up.	Boiler water temperature OK? Valve does not open after the summer heating break - is it scaled?	Correct boiler water temperature, remove GENIUS LED 100. Move the valve tappet back and forth several times by hand/tool.
Radiator does not get cold.	Valve does not close completely. The closing point of your valve seal may have shifted.	Perform new adaptation (see „Adaptation“) Move the valve tappet several times by hand - adaptation may not be possible because the valve may have scaled or the seal no longer fulfils its function.
Thrust piece falls out. 	An endless thread can cause the thrust piece located on the underside to fall out if the controller has not been applied to the valve.	Insert thrust piece. Press the OK -button or perform adaptation of the device by removing and reinserting the batteries. The endless thread now turns and tightens the thrust piece again. Attach to radiator and perform adaptation again.
The LED for Assembly/Dis-assembly flashes 	Assembly error, no adaptation possible <ul style="list-style-type: none"> ▪ GENIUS LED 100 is not mounted on the radiator ▪ Valve stroke too short ▪ no valve movement possible 	Mount the device correctly on the radiator. If required, use a suitable adapter from the included accessories or other adapters from our web shop at www.eurotronic.org .
The LED for battery flashes continuously. 	Battery low	Insert new batteries.
The LED for Fast-Link flashes at an increased frequency 	Fast-Link transmission was not successful.	Increase the brightness of your smartphone display to the highest level. After you have selected the Fast-Link function on the controller and the controller is ready for transmission, press the button „Transmit settings“ and hold your smartphone close to the controller.

11. TECHNICAL SPECIFICATIONS

GENIUS LED 100

Name of device	GENIUS LED 100
EAN	4260012711356
Article Number	700070
Supply Voltage	2 x 1,5V LR6/Mignon/AA
Connection	M30 x 1,5mm
Method of operation	Type 1
Dimensions (W x H x D)	56 x 68 x 89 mm
Weight	149,7 g (incl. batteries)
Degree of protection	IP20
Degree of pollution	2

Technical modifications are subject to change. All descriptions for compatibility are without engagement.

12. SUPPORT AND CONTACT

For technical support for the Eurotronic products, please contact Eurotronic via e-mail or telephone:

Customer Service: **Eurotronic Technology GmbH**

Südweg 1
36396 Steinau-Ulmbach
Germany

telephone: +49 (0) 6667 91847-0

e-mail: info@eurotronic.org

13. ENVIRONMENTAL INFORMATION

GENIUS LED 100

From the date of transposition of the European Directives 2012/19/EU into national law, the following shall apply:

Electrical and electronic devices as well as batteries must not be disposed of with household waste.



The consumer is legally obliged to return electrical and electronic equipment and batteries at the end of their service life to the public collection points set up for this purpose or to the point of sale. Details are regulated by the respective national law.

Batteries and rechargeable batteries must not be disposed of with household waste!



As a consumer, you are legally obliged to dispose of all batteries and rechargeable batteries, no matter whether they contain harmful substances* or not, at a collection point in your municipality/city district or in the respective stores, so that they can be disposed of in an environmentally friendly manner.

*labelled with: Cd = cadmium, Hg = mercury, Pb = lead

Dispose of Packaging:



Dispose of the packaging sorted by type. Add paperboard and cardboard to the waste paper, foils to the recyclables collection. Dispose of the packaging sorted by type. Add paperboard and cardboard to the waste paper, foils to the recyclables collection.

The symbols on the product, the instruction manual or the packaging refer to these regulations. By recycling, material utilisation or other forms of utilisation of old devices/batteries, you make an important contribution to the protection of our environment.



Declaration of Conformity:

Eurotronic Technology GmbH hereby declares that the GENIUS LED 100 radiator thermostat complies with all applicable European Economic Area regulations of Directive 2014/53/EU. The full text of the EU Declaration of Conformity is available at the following Internet address: <https://eurotronic.org/service/downloads>.

The Apple Logo, iPad und iPhone are brands of Apple Inc., which are registered in the USA and other countries. App Store is a service brand of of Apple Inc. Google Play, Android and other brands are brands of Google Inc.

14. WARRANTY

The two-year warranty begins on the day of purchase. Please keep the receipt as evidence of purchase in the future. During the guarantee period, defective radiator thermostats may be sent to the service address below. Please ensure sufficient postage is paid.

A new or repaired device will then be sent to you free of charge. There is no new warranty period starting when repairing or replacing the device. Please note that we only grant warranty on the function of the device. We will not grant warranty for the interaction between the thermostat and the bottom part of the valve. The technical data is only valid for the use of the following valves: Heimeier, Junkers Landys+Gyr, MNG, Honeywell Braukmann (measure of thread M30x1,5), Oventrop (M30x1,5) Danfoss RA, RAV und RAVL.

Please see the combinations of the devices on our website (www.eurotronic.org/service/faq/)

Following expiry of the warranty, you may still send the defective device to the address below for repairs. Please ensure sufficient postage is paid. Repairs carried out after the guarantee are subject to a charge. Your legal rights are not affected by this guarantee.



Eurotronic Technology GmbH
Südweg 1 | 36396 Steinau-Ulmbach | Germany
www.eurotronic.org

08/2019